

PRODUCT DESCRIPTION

EZ171036

The idea is to make an inlet manifold which can be used for tractors with different pump types for the external hydraulic system. It means fixed displacement, LS variable pumps or variable pressure compensated pumps.

Manifold produced by EUROFLUID. Hydraulic scheme and layout for manifold design made by Dani-tech. This manifold is made to get a more compact valve block and flexibility in configuration of the inlet manifold.

EUROFLUID supply the manifold without any valves and orifices. All cavities are made for Hydraforce cartridges.

The manifold EZ171036 has flange connection P2 [Cetop 3] and P4 [Cetop 5] so it's possible to mount parallel blocks directly on the P1 and T1 ports. Connections to P2 and T2 have to be made with hose or pipe. Following picture show EZ171036 with the block EZ171002/1



This solution replace the old system with manifold HF19763-02 and a separate EM213/.. manifold with Cetop 3 valves like shown on following picture:



The new design in EZ171036 gives flexibility in valve configuration. It's now possible to put in pressure compensated flow regulator valves in P1 and P2 lines. It can be fixed, manual or proportional operated valves. See following possible valve configuration:

VC10-3

FR10-33, FR10-39 and PV70-30 valves.
SAE plug 6103010 to close the cavity if no valve is assembled.

VC10-2A

SV10-22 valve
CP10-20-N
Cavity plug need a drilling to make the orifice between port 1 and 2. Used to make flow restriction to P1.
SAE plug 6103010 to close the cavity if no valve or CP plug is assembled.

It's also possible to operate continuously at P2 with the correct LS signal if the P1 line is closed with SV10-22.

VC08-2

SV08-25M, SV08-21 valves
SC08-20 filterscreen + ORF4 Orifice disc – Do not use ORF3 orifice.

VC12-2B

FR12-20F, FR12-23 and PV72-20
SAE plug 6103012 to close the cavity if no valve or CP plug is assembled.

VC08-3

LS08-30-0-N
SAE plug 6103008 to close the cavity if no valve is assembled. Used if there are no user on P2.

VC12-S3

It's important to chose the right EP12-S35 compensator to ensure that the flow regulator valves work correct which means keep a constant flow in P1 or P2 line independent of the working pressure.

EP12-S35M-0-N-80 → Spring 5,5bar/80psi – Manual override “for closed center”
May be used if the manifold contains any of following listed valves:
SV10-22, ORF1

EP12-S35-0-N-160 → Spring 11bar/160psi
Must be used if the manifold contains any of following listed valves:
FR10-33, FR10-39, PV70-30 and FR12-20F valves

EP12-S35M-0-N-240 → Spring 16,5/240psi
Must be used if the manifold contains any of following listed valves:
FR12-23 and PV72-20

Use always ORF2 0,8mm together with EP12 valve
Please note it's only possible to make manual override on EP12-S35M valve. Use
CP12-S30-N - Plug to make Closed center for LS and pressure compensated pumps.

ORF1

Orifice disc 7063__ __ Can only be used together with SV10 valve.

Last 3 digits indicate the drill-thru diameter in inches. 7063**157** = .157x25,4=3,99mm

Orifice can be used when there is no user on P2. The EP valve or LS pump make the flow pressure compensated to P1

ORF2,3

Orifice plug M8x1

Standard size 0,8mm code 545030529

In some LS systems it can be needed to change ORF3 to a bigger diameter to ensure that the LS flow to the tractor is big enough to create the needed working pressure on p line.

ORF4

Orifice plug M8x1 0,2mm code AGF1080802. Can be used together with filter screen SC08-20

Orifice and filter screen is mainly used together with SV10-22 in VC2 and no orifice in ORF3

P2, T2 connection

We have in stock following subplates with LS output. Have to be used with directional valves with A and B port unloaded to tank in neutral position like DS3-S3 or DS5-S3 valves.

The valve SV10-22 have to be used if any valves connected to P2 and T2 work with flow limitation, it means with a valve in VC4 or external orifice. The SV10-22 have to be used in VC2 and it close the P1 line so the flow doesn't go to the directional valves with closed P port. Then we avoid to get a LS signal from P1 line which will mean max. working pressure from pump.

EZ171022 – NG06 subplate for 1 pcs. Valve

EZ171024 – NG10 subplate for 1 pcs. Valve

Following sheets shows:

Manifold design

Hydraulic scheme

Pressure drop P->T with EP12-S35M-0-N-80 valve

Pressure drop P->T with EP12-S35-0-N-160 valve

Pressure drop P->P1

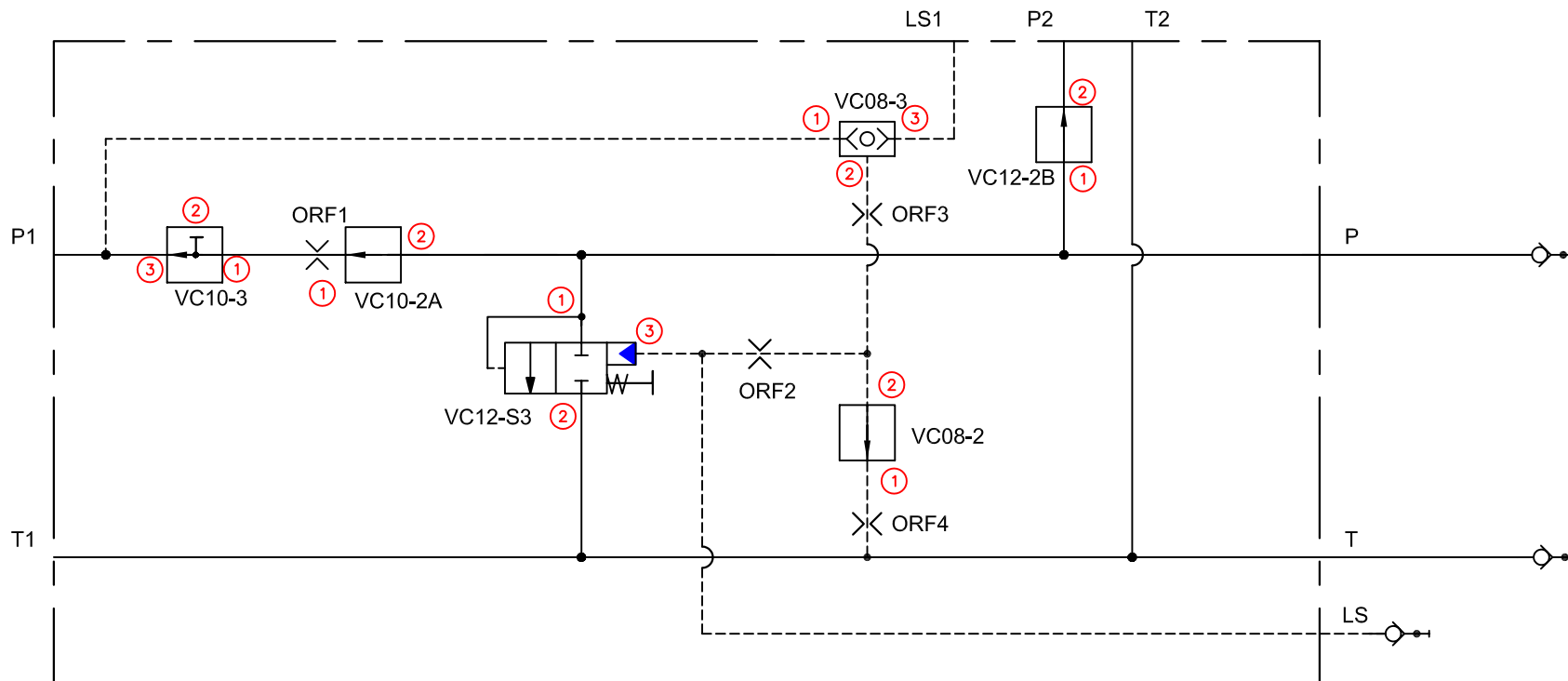

CAVITY:

VC12-S3 = EP12-S35

VC08-3 = LS08-30

VC10-3 (Only 2-ported function) = PV70 or FR1033/39

VC10-2A = SV10-20 or SP10-20

VC08-2 = SC08-20 or SV08-21

VC12-2B = FR12-20/23 or PV72-20

ORF1 = Orifice Disc 7063

ORF2 = Orifice Plug M8x1 (Only thread - 0,8mm ->545030529)

ORF3 = Orifice Plug M8x1 (Only thread - 0,8mm ->545030529)

ORF4 = Orifice plug M8x1 (Only thread - 0,2mm -> AGF1080802)

PORTS:

P, T, P2, T2 = 3/4" BSPP

LS, LS1 = 1/4" BSPP

P1, T1 = 1/2" BSPP (P2/P4)

Application BM	Drawing BM	Approved BM	Drawing no. 5708	Date 5/4-2005	Scale
Dani-tech			Description INLET MANIFOLD		
Denmark. ☎+45-76342300 📠+45-76342301			Item no. EZ171036		Sheet 1/1
Sweden. ☎+46-46233060 📠+46-46233069					
Nederland. ☎+31-715417704 📠+31-715419106					

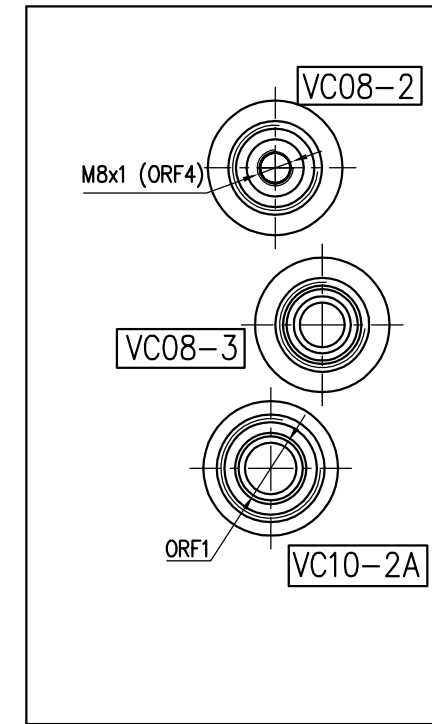
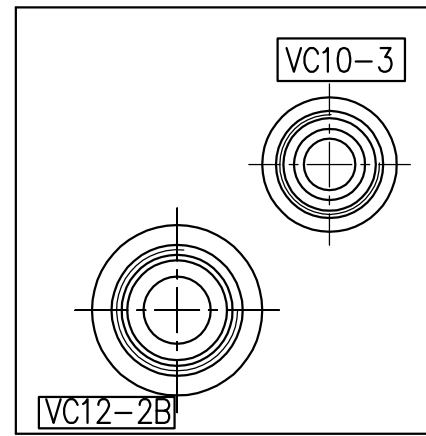
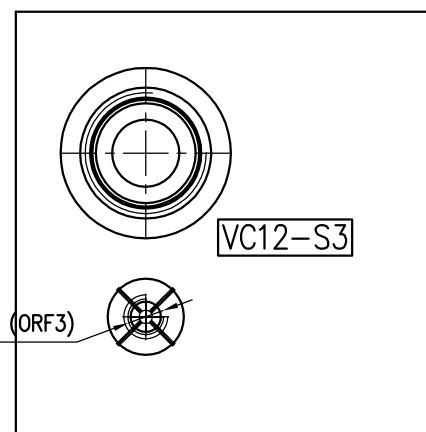
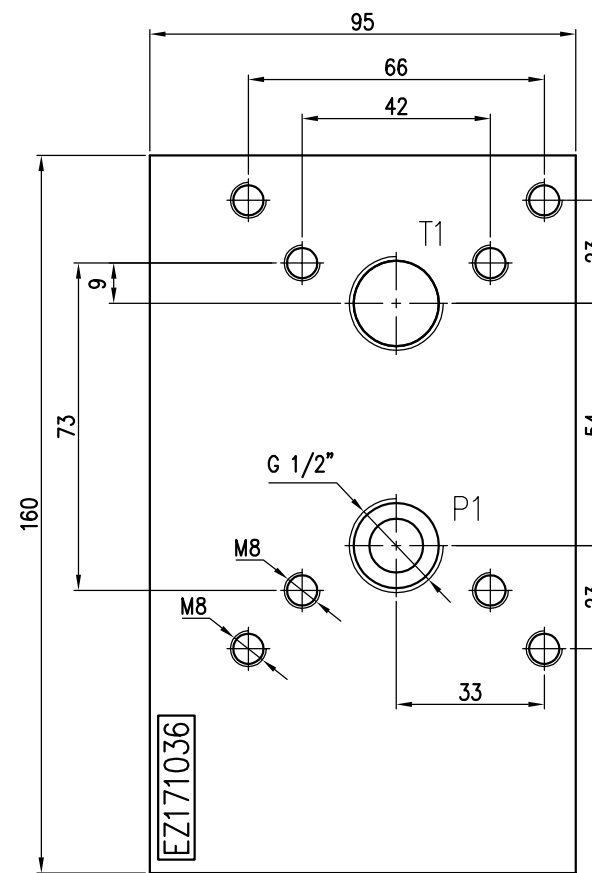
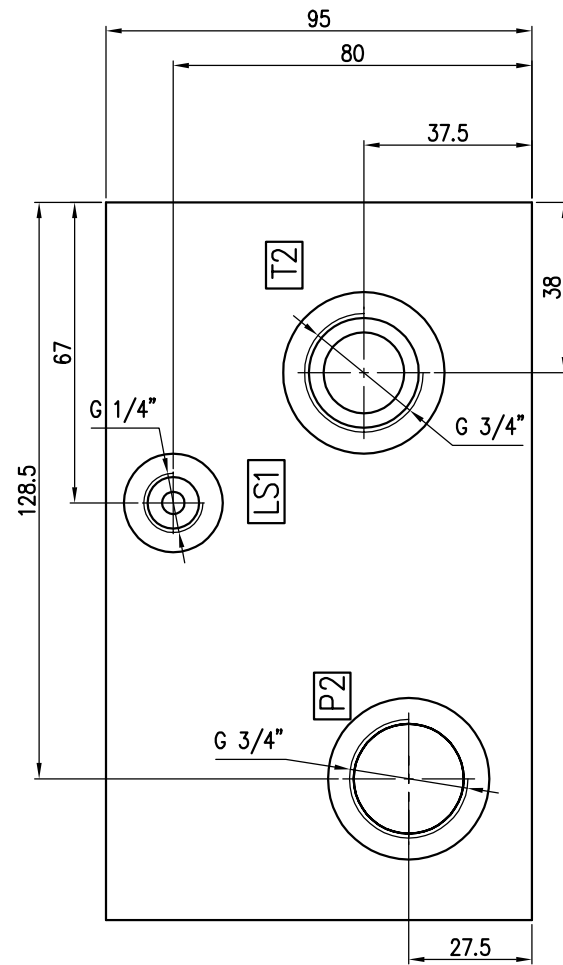
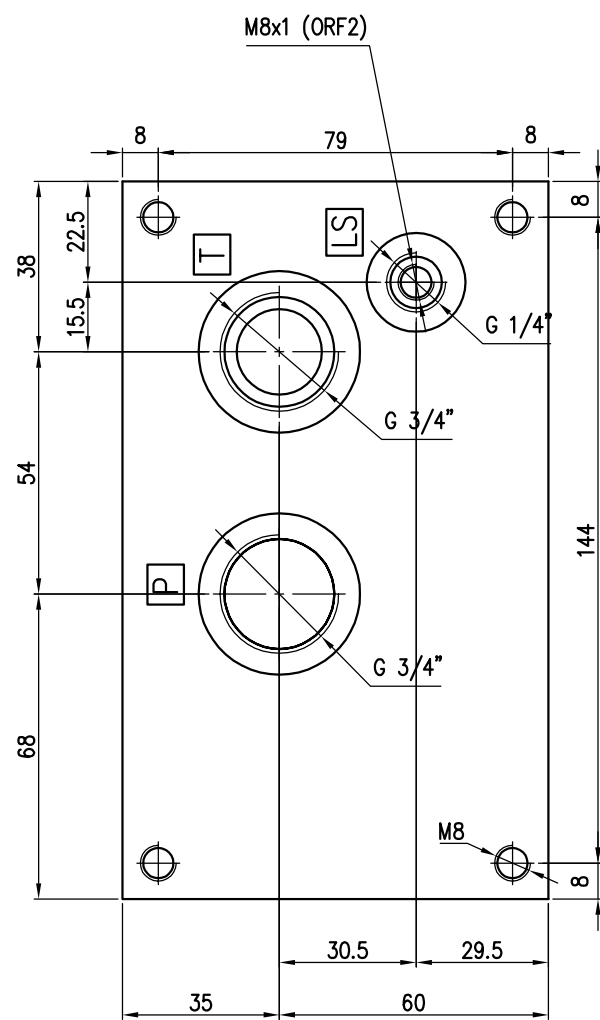

- EP1=VC12-S3
- SV1=VC10-2 Variation "A"
- SC1=VC08-2
- LS1=VC08-3
- ORF1=Orifice Disc 7063
- ORF2=Orifice plug M8x1 (Only thread)
- ORF3=Orifice plug M8x1 (Only thread)
- ORF4=Orifice plug M8x1 (Only thread)
- VC1=VC10-3 (Only 2-ported function)
- VC2=VC12-2 Variation "B"

Diseg./Drawn M.V.	Data/Date 04/05/2005	App./Approved	Data/Date	Materiale/Material G25
Denominazione/Title MANIFOLD				Finitura/Finish BLACK PAINTED
HYDRAULIC CIRCUIT				Direttorio/Cartella/File Spec/incorso/Studi/
T29406				Scala/Scale /
Codice/Drawing number EZ171036				I.R. 03

EZ171036 - EP12-S35M 80psi

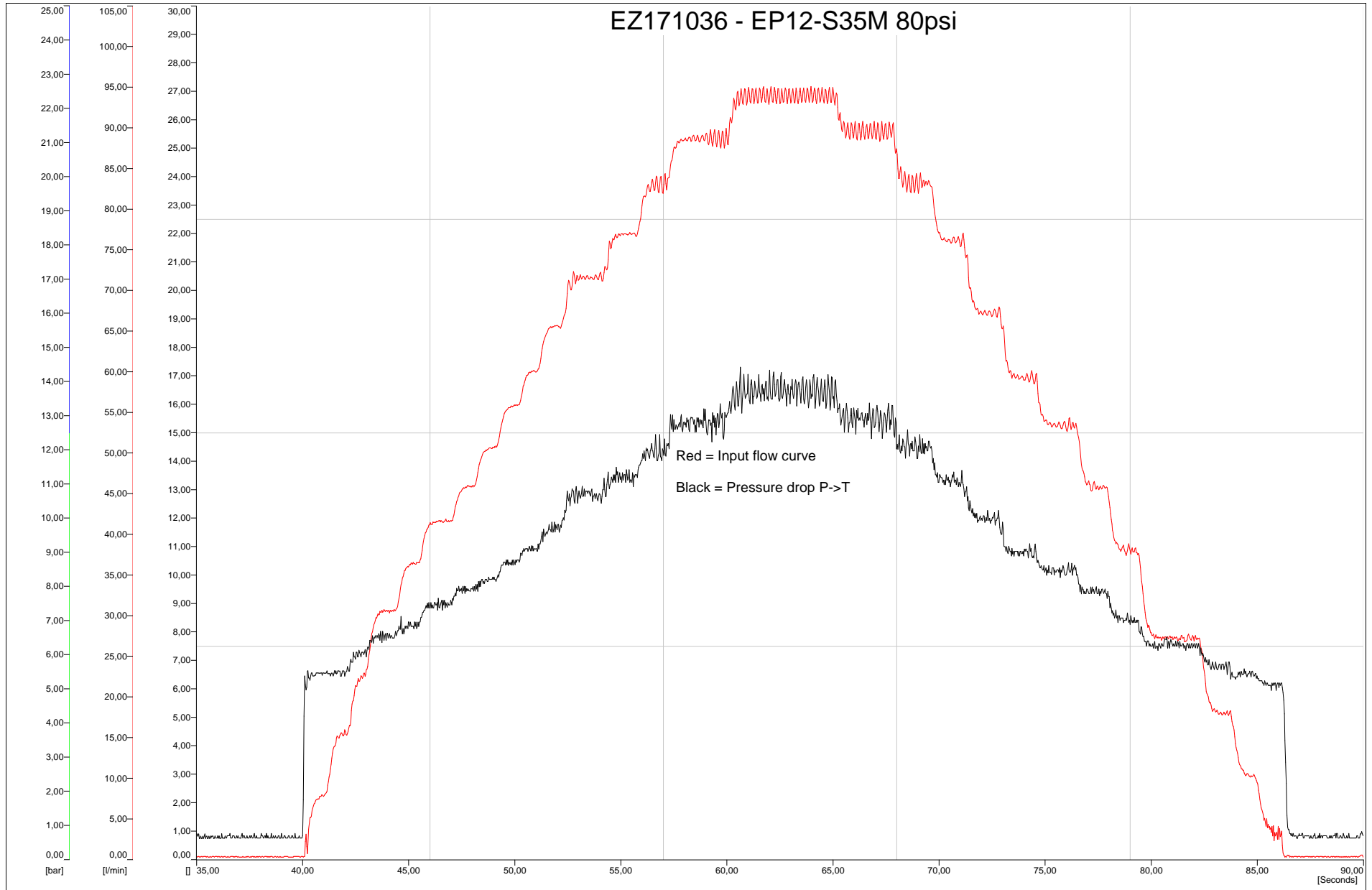

EZ171036 - EP12-S35 160psi

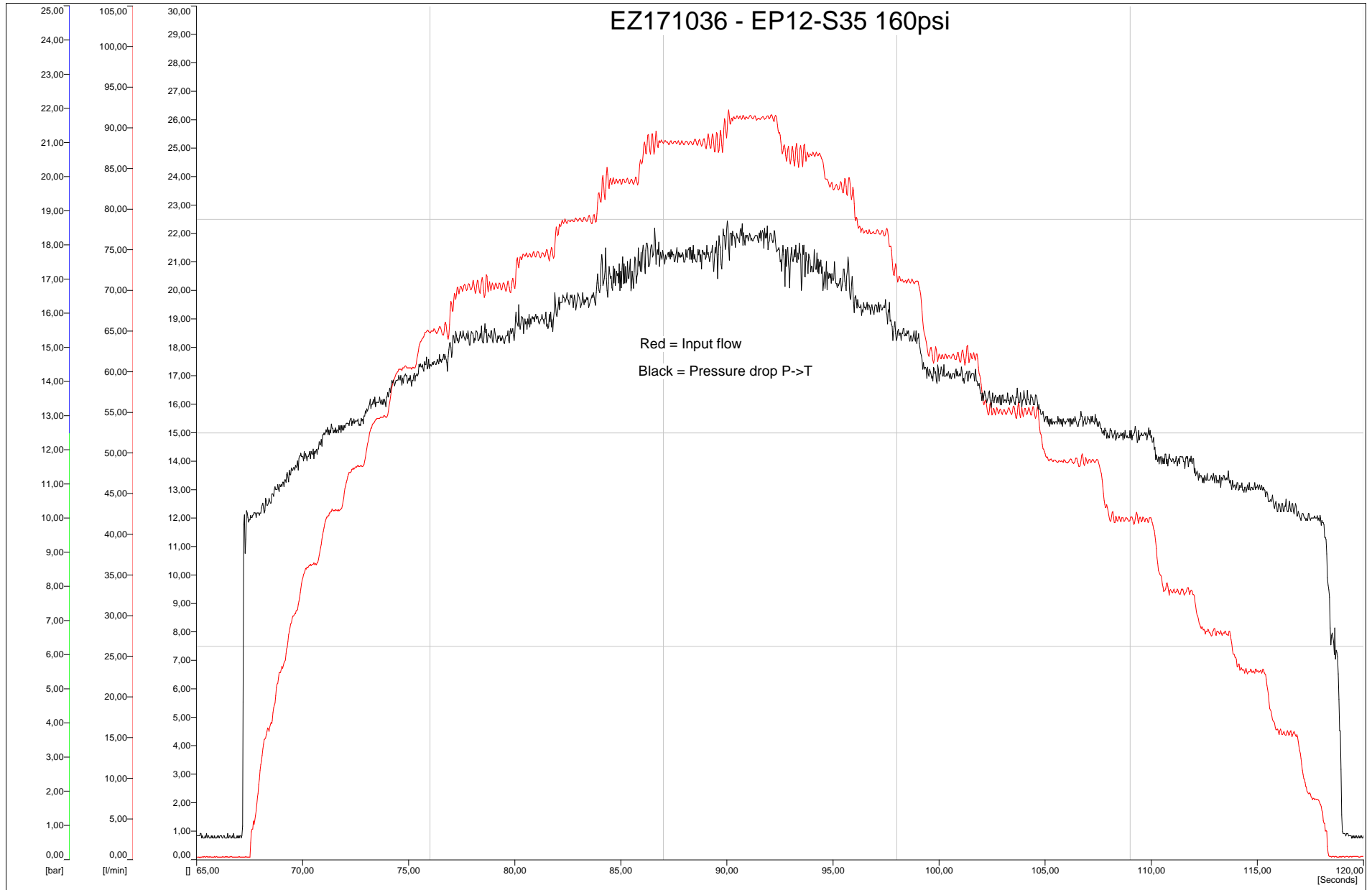

Trykfald P -> P1

